

Downflo® Dust Collectors

Models DFT 2-4 through 4-128



DFT 3-24

- ExtraLife™ filter cleaning system lengthens filter life.
- EZ Ultra-Web® II filters provide the longest filter life and highest filtration efficiency.
- Bridge-free hopper and a proprietary drum-full indicator ensure reliable, trouble-free performance.
- Inclined cartridges and quick removal access covers result in easier maintenance.
- Checker™ board control panel displays color-coded operating and diagnostic information.
- Proprietary cartridges optimize performance in fibrous, nonfibrous, agglomerative, and high temperature applications.

ExtraLife™ Filter Cleaning System

The ExtraLife filter cleaning system uses proprietary venturies to deliver more cleaning energy. The result is longer filter life and more reliable performance. The graph shows pulse energy measured one inch from the tubesheet. ExtraLife technology is in blue; conventional technology is in black.

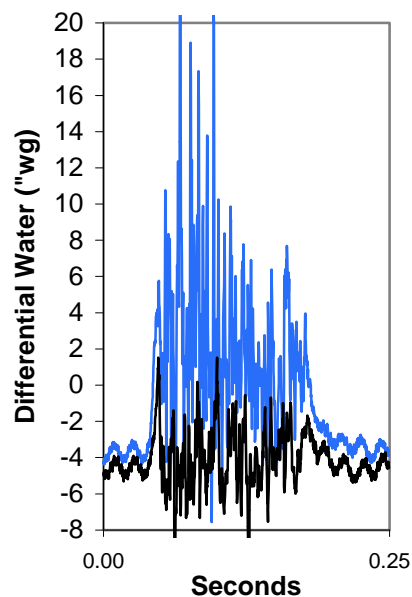
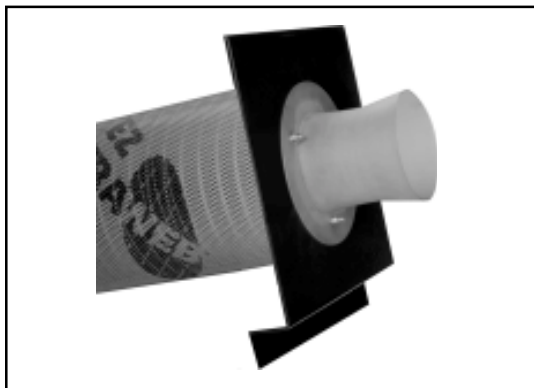

Cartridge Technology



EZ Ultra-Web® II, Ultra-Web® II NL, Thermo-Tek®, Fibra-Web®, and Torit-Tex™

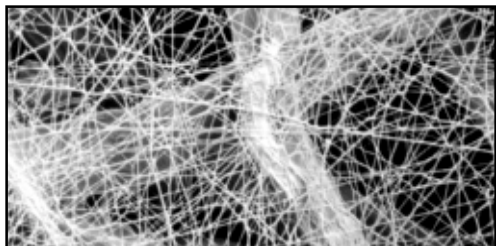

EZ Ultra-Web II Media (600X)

- EZ Ultra-Web II cartridges feature Eon™ Fine Fiber Technology by Donaldson. Eon microfibers ensure longest filter life and highest filtration efficiency.

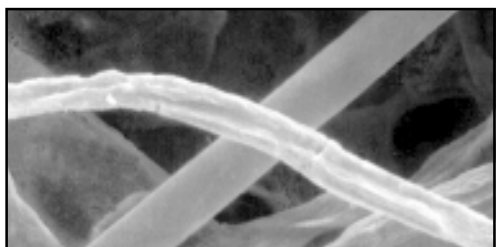

Competitive Media (600X)

- Competitive media has no surface layer of microfibers. (Competitive media magnified 600X.)



Control Panel Options

- The Checker™ board Control Panel provides color-coded diagnostic data.
- The Torit Delta P Control provides filter restriction and cleaning control at the set points you choose.

- Octagonal hopper with no internal ledges prevents bridging and plugging problems.

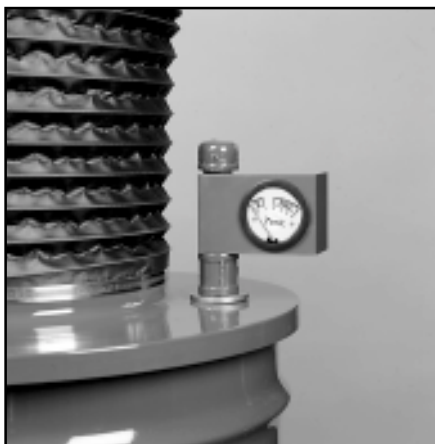
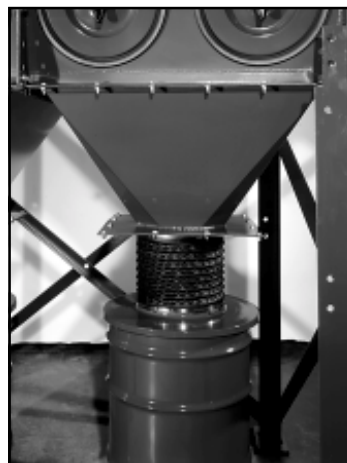

- Drum Sentry™ indicates when drum is full.

- Inclined cartridges and quick removal access covers for easy filter changeout.



Operating Explanation

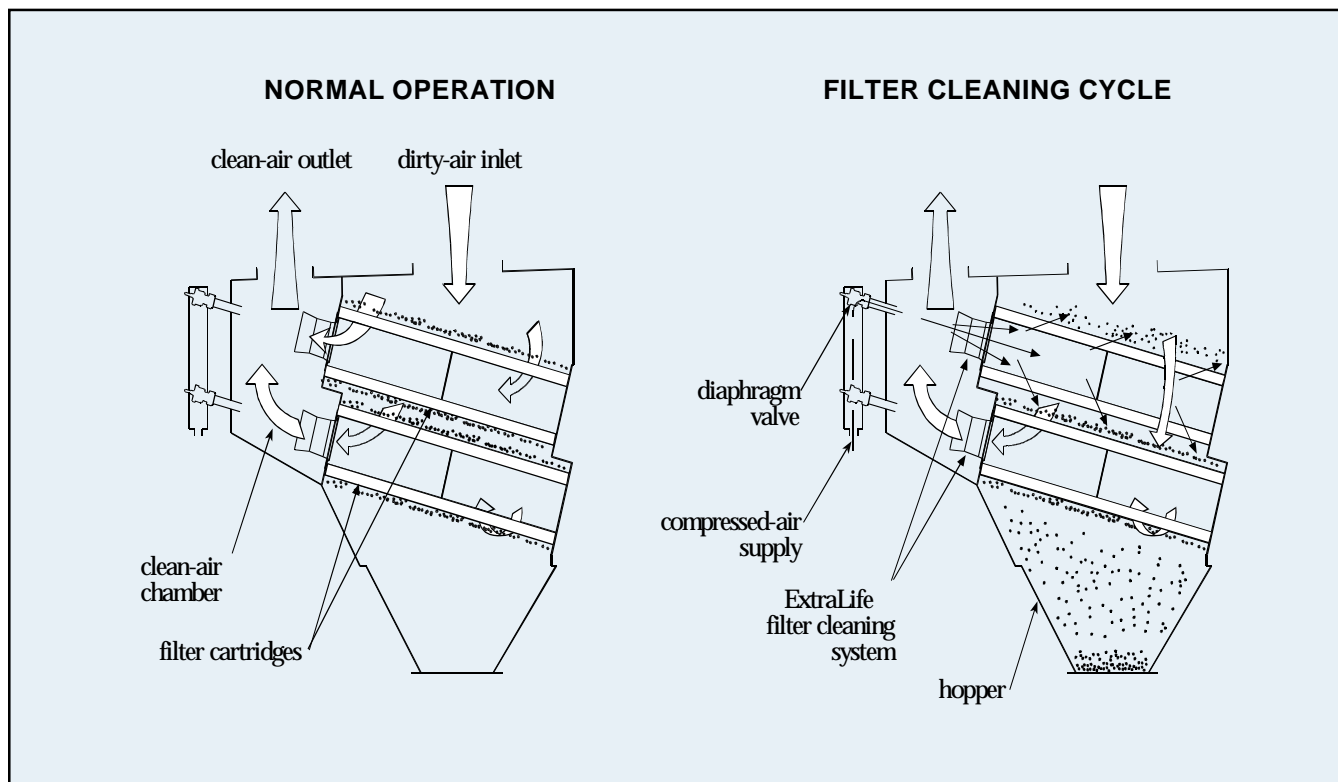

Specifications

Model	No. of Filters	EZ Ultra-Web II Filter Area ft ²	No. of Valves	Shipping Weight lbs
DFT 2 - 4	4	1,016	4	1,050
2 - 8	8	2,032	4	1,790
2 - 12	12	3,048	6	2,305
2 - 16	16	4,064	8	2,970
2 - 24	24	6,096	12	3,890
2 - 36	36	9,144	18	5,650
DFT 3 - 6	6	1,524	6	1,300
3 - 12	12	3,048	6	2,180
3 - 24	24	6,096	12	3,510
3 - 36	36	9,144	18	4,850
3 - 48	48	12,192	24	6,350
3 - 60	60	15,240	30	7,690
3 - 72	72	18,288	36	9,010
DFT 4 - 16	16	4,064	8	2,510
4 - 32	32	8,128	16	4,045
4 - 48	48	12,192	24	5,605
4 - 64	64	16,256	32	8,340
4 - 80	80	20,320	40	9,480
4 - 96	96	24,384	48	11,135
4 - 112	112	28,448	56	13,065
4 - 128	128	32,512	64	14,715

All Models	
Seismic rating Zone 4
Wind load rating (mph) 100
Housing rating (inches H ₂ O) ±20
Compressed air required (psig) 90-100
Power (valves & controls) 120 VAC 50/60 Hz

Front Profile

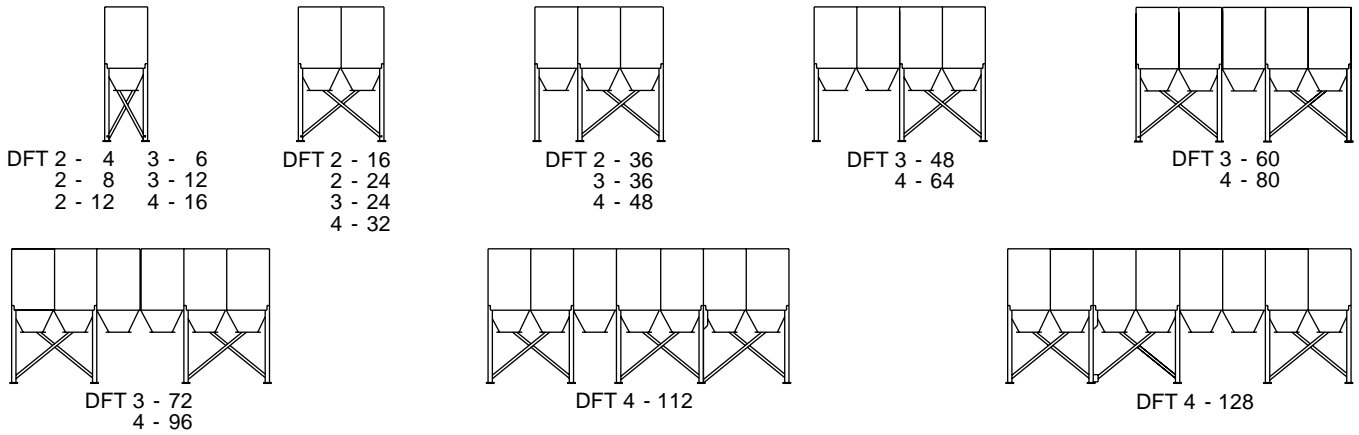

Larger units may ship in two sections.

Dimensional Information

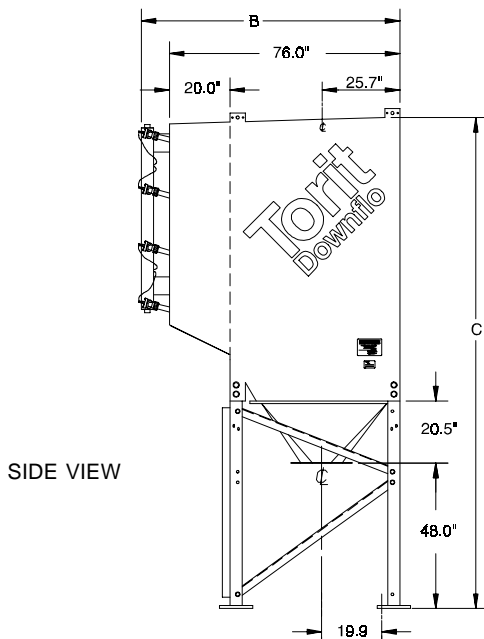
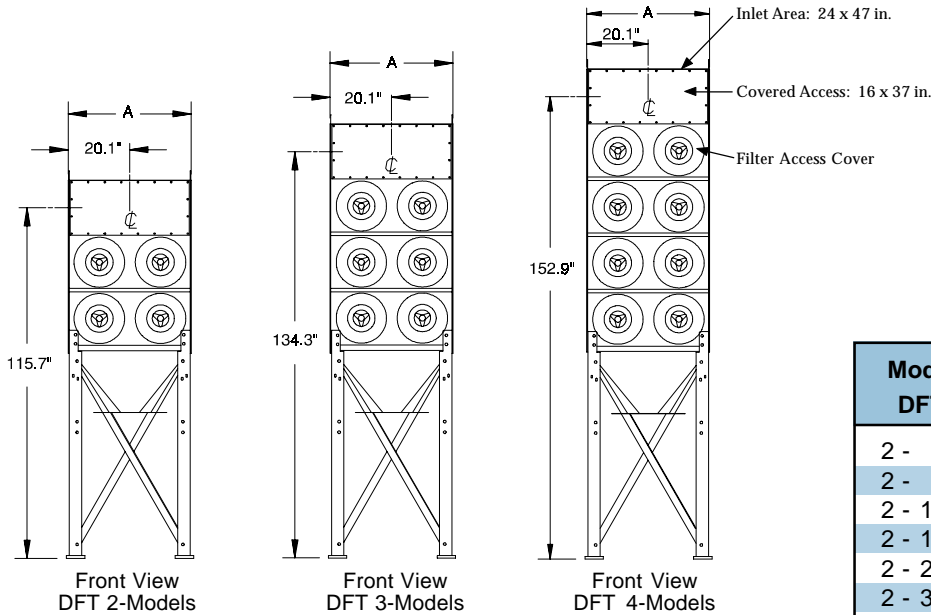

Model* DFT	"A" in	"B" in	"C" in
2 - 4**	40.2	60.8	118.7
2 - 8	40.2	85.3	124.9
2 - 12	58.2	95.0	124.9
2 - 16	80.2	85.3	124.9
2 - 24	116.2	95.0	124.9
2 - 36	174.2	95.0	124.9
3 - 6**	40.2	60.8	137.4
3 - 12	40.2	85.3	143.5
3 - 24	80.2	85.3	143.5
3 - 36	120.2	85.3	143.5
3 - 48	160.2	85.3	143.5
3 - 60	200.2	85.3	143.5
3 - 72	240.2	85.3	143.5
4 - 16	40.2	85.3	162.1
4 - 32	80.2	85.3	162.1
4 - 48	120.2	85.3	162.1
4 - 64	160.2	85.3	162.1
4 - 80	200.2	85.3	162.1
4 - 96	240.2	85.3	162.1
4 - 112	280.2	85.3	162.1
4 - 128	320.2	85.3	162.1

* The first number indicates number of filter rows, and the second number indicates number of cartridges.

** All models except DFT 2-4 and DFT 3-6.

Torit Downflo Dust Collectors

Standard Features

- ExtraLife Filter Cleaning
- EZ Ultra-Web II Filters (crushable)
- Checker Board Control Panel or Torit Delta P Control
- Bridge-Free Hopper
- Quick Removal Access Covers
- 10-Year Warranty

Cartridge Filter Options

- Ultra-Web II
- Ultra-Web II NL (no outer liner)
- Ultra-Web II FR (Flame Retardant)
- Ultra-Web II FR NL
- Fibra-Web® —Fibrous Dust
- Fibra-Web FR (Flame Retardant)
- Torit-Tex™—Agglomerative Dust
- Thermo-Tek® (up to 275°F/135°C)

Equipment Options

- Abrasion Resistant Inlets
- Air Management Module
- Extended Dirty Air Plenum
- Drum Sentry Drum-Full Indicator
- Bag Out Filter Removal Kit
- Cold Climate Kit
- Heavy Duty Cold Climate Kit
- Direct Drive Fans
- Damper Pack
- Chamber and Exhaust Silencers
- Explosion Vents
- Magnehelic®* Gauge
- Photohelic®* Gauge
- Rotary Valves and Transitions
- Slide Gates
- Drum Cover and Hose
- Service Platform

* Magnehelic and Photohelic are registered trademarks of Dwyer Instruments, Inc.

Information contained in this document is subject to change without notice.



Donaldson Company, Inc.
Dust Collection Group
P.O. Box 1299
Minneapolis, MN 55440
800-365-1331
www.torit.com
e-mail: dustmktg@mail.donaldson.com

U.S. Patent 5,882,379
© 1995 Donaldson Co., Inc.
Printed in U.S.A.
Printed on Recycled Paper 

Form Downflo (DFT) 06/01